

# metos

## BRATT PAN

**FUTURA HD**  
**TYPE: 100,150, 200**

Accessories

WATER FILLING, HOSE REEL WITH HAND SHOWER, STRAINER PLATE, REMOTE CONTROL

## Installation and Operation Manual



Rev.: 1.2 (15.6.2026)

3756394, 3756283, 3756248

## Contents

<b>1.</b>	<b>General</b> .....	<b>3</b>
1.1.	Symbols used in the manual.....	3
1.2.	Symbols used on the appliance.....	3
1.3.	Checking the relationship of the appliance and the manual.....	3
<b>2.</b>	<b>Safety</b> .....	<b>4</b>
2.1.	Safe use of the appliance.....	4
2.2.	Safety instructions in case of malfunction.....	4
2.3.	Disposal of the appliance.....	4
<b>3.</b>	<b>Functional description</b> .....	<b>4</b>
3.1.	Intended use of the appliance.....	4
3.1.1.	Use for other purposes.....	4
3.2.	Operating principle.....	4
3.3.	Accessories.....	5
<b>4.</b>	<b>Operation instructions</b> .....	<b>6</b>
4.1.	Before use.....	6
4.1.1.	Preparing the use.....	6
4.2.	Operation.....	6
4.2.1.	Switching on the bratt pan.....	6
4.2.2.	Setting of the frying temperature.....	8
4.2.3.	Frying temperature.....	8
4.2.4.	Tilting.....	8
4.2.5.	Filling the water (optional).....	9
4.3.	After use.....	9
4.3.1.	Cleaning.....	9
4.3.2.	Service.....	10
<b>5.</b>	<b>Installation</b> .....	<b>11</b>
5.1.	General.....	11
5.1.1.	Operating conditions.....	11
5.1.2.	Storage.....	11
5.2.	Transporting and unpacking the bratt pan.....	11
5.3.	Positioning the bratt pan.....	12
5.3.1.	Leveling of the bratt pan.....	12
5.4.	Connections.....	13
5.4.1.	Electrical connection.....	14
5.4.2.	Water connection (optional).....	14
5.5.	Test-run.....	14
<b>6.</b>	<b>Troubleshooting</b> .....	<b>15</b>
6.1.	Troubleshooting Futura HD 100.....	15
6.2.	Troubleshooting Futura HD 150, Futura HD 200.....	16
<b>7.</b>	<b>Technical specifications</b> .....	<b>17</b>

## 1. General

Carefully read the instructions in this manual as they contain important information regarding to proper, efficient and safe installation, use and maintenance of the appliance.

Keep this manual in a safe place for eventual use by other operators of the appliance.

The installation of this appliance must be carried out in accordance with the manufacturer's instructions and following local regulations. The connection of the appliance to the electric and water supply must be carried out by qualified persons only.

Persons using this appliance should be specifically trained in its operation.

Switch off the appliance in case of failure or malfunction. The periodical function checks requested in the manual must be carried out according to the instructions. Have the appliance serviced by a technically qualified person authorized by the manufacturer and using original spare parts.

Not complying with the above may put the safety of the appliance in danger.

### 1.1. Symbols used in the manual



This symbol informs about a situation where a safety risk might be at hand. Given instructions are mandatory in order to prevent injury.



This symbol informs about the right way to perform in order to prevent bad results, appliance damage or hazardous situations.



This symbol informs about recommendations and hints that help to get the best performance out of the appliance.

### 1.2. Symbols used on the appliance



This symbol on a part informs about electrical terminals behind the part. The removal of the part must be carried out by qualified persons only.

### 1.3. Checking the relationship of the appliance and the manual

The rating plate of the appliance indicates the serial number of the appliance. If the manuals are missing, it is possible to order new ones from the manufacturer or the local representative. When ordering new manuals, it is essential to quote the serial number shown on the rating plate.

## 2. Safety

### 2.1. Safe use of the appliance



Because the bratt pan is a heated appliance that has hot surfaces during normal use, the following warnings and instructions must be followed to avoid burns:

- During long-time operation the sides of the bowl, the pouring nose and the lid get hot.
- For safe frying, always use heat protective gloves and appropriate accessories.
- Look out for discharging steam when opening the lid, especially when simmering or stewing.
- Do not leave the bratt pan on for long periods totally without supervision.



It is strictly forbidden to use bratt pan as a deep fat fryer.

### 2.2. Safety instructions in case of malfunction



Switch off the appliance if it is damaged or malfunctioning. Contact authorised service personnel using original spare parts for service of the appliance.

### 2.3. Disposal of the appliance

The destroying of the appliance when the end of its economical lifetime has been reached must be carried out in accordance with local rules and regulations. Taking care of substances that might be harmful to the environment, if not properly handled, and utilization of reusable materials is best done by using professional personnel specializing in recycling.

## 3. Functional description

### 3.1. Intended use of the appliance

Futura HD bratt pan is intended for heating, frying and stewing, braising, boiling of food.

#### 3.1.1. Use for other purposes



Use of the appliance for other purposes than stated above is prohibited.



The manufacturer of the appliance takes no responsibility for situations that may occur if warnings and instructions in this manual are neglected.

### 3.2. Operating principle

Bratt pan is heated by specially designed heating elements which evenly heat up cooking base. Cooking base is divided into two cooking zones in models Futura HD150 and Futura HD200. Each zone is controlled individually by own thermostat. Green and yellow pilot lamp is on when corresponding zone is activated. Yellow pilot light goes off when the preset cooking temperature of corresponding zone is reached. Cooking base of model Futura HD100 has only one cooking zone.

Tilting of bratt pan is actuated by electrical motor. Tilting and returning is controlled by corresponding push buttons on the control panel.

### 3.3. Accessories

Each model of pan may have the following optional accessories (refer to the below picture):

- Cold water filling  
Cold water from network is poured into the bowl through the spout built into the lid. Amount of cold water can be measured by measuring stick which must be fixed on the wall of bowl. Cold water connection G3/4 inch is located on the rear wall of support pillar. Water filling is controlled via button on the control panel.
- Hose reel with hand shower  
Hose reel is built into the support pillar. Hand shower with retractable hose and shut off valve is located on the cover of support pillar.
- Wired remote control for tilting  
Wired remote control can be used for tilting and returning of the pan bowl instead of doing it via buttons on the control panel. Remote control is fixed on the front wall of the control pillar.
- Strainer plate  
Strainer plate is placed on the top of the bowl and secured on it with grips. Strainer plate is made from stainless steel.

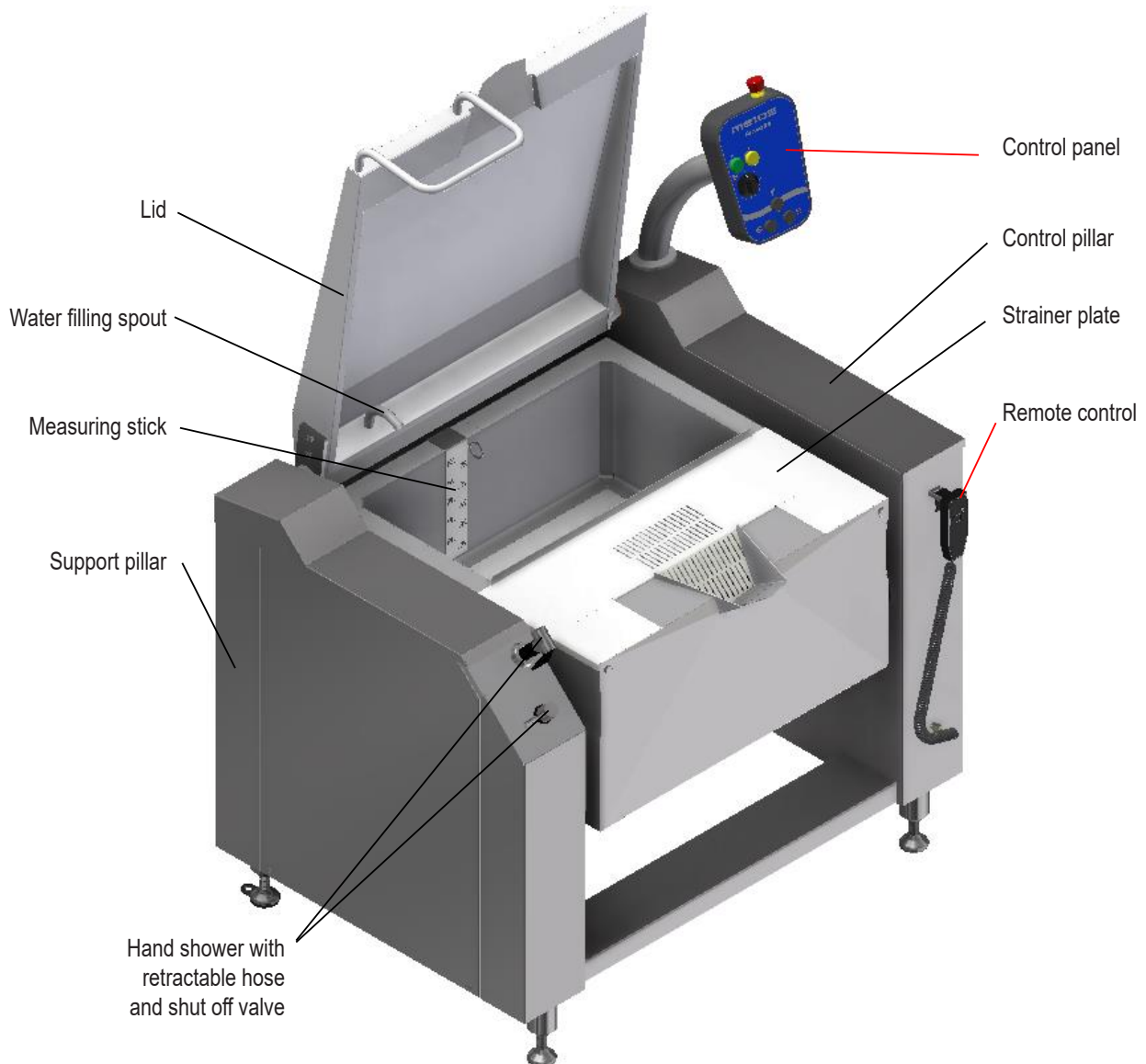

## 4. Operation instructions

### 4.1. Before use

#### 4.1.1. Preparing the use



**Using the appliance for the first time or when heating elements have been changed**, turn on the bratt pan at MINIMUM temperature for SEVERAL hours or until the insulation resistance is OK. This allows remaining humidity in the heating elements to dry up. In fact, on first connection, the earth insulation can be relatively inadequate, but after the above-mentioned initialization run the insulation level will normally be re-established according to CEI 18-6 part 307 regulations.



Setting the power or temperature to maximum right away at first run may damage the heating elements.

In unclear cases contact our technical support:  
[technical.support@metos.com](mailto:technical.support@metos.com)

After the cleaning, the frying surface must be burned in with salt-free grease. Heat up the pan to 200°C keeping the lid closed. Burn the grease for 5-10 minutes, let the pan cool down and wipe off excessive grease. Repeat when necessary. Do not use oil for burning. Heated oil would create a tough surface, which is difficult to clean. A well greased pan reduces fat consumption in frying and minimizes burning of foodstuffs.

### 4.2. Operation

#### 4.2.1. Switching on the bratt pan

Turn mains switch of bratt pan in „I“ position. Main switch is located on rear wall of control pillar. Further operations with bratt pan are controlled from the operating panel.

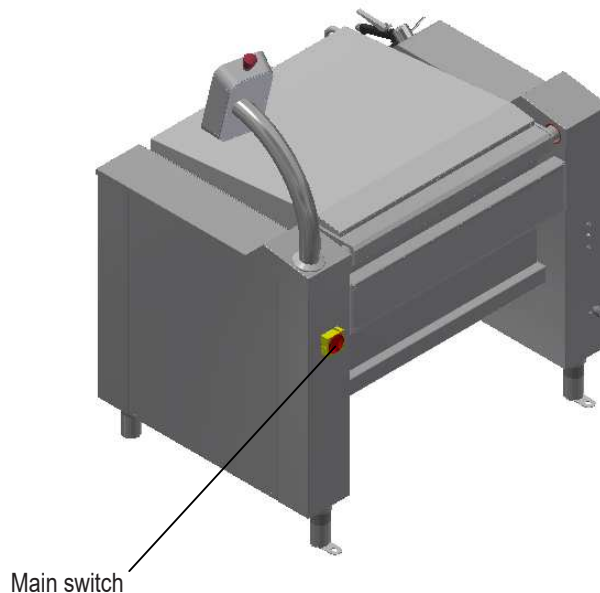



Operating panel Futura HD 150L, Futura HD 200L

1. EMERGENCY STOP button
2. Temperature adjustment of left cooking zone
3. Temperature adjustment of right cooking zone
4. Yellow signal lamp. Heating of left cooking zone is on.
5. Green signal lamp. Left cooking zone is activated.
6. Yellow signal lamp. Heating of right cooking zone is on.
7. Green signal lamp. Right cooking zone is activated.
8. Water filling (optional)
9. Tilting of pan bowl
10. Return of pan bowl

Heating up to the frying temperature takes about 3-8 minutes. When the preset frying temperature is reached, the yellow pilot light goes off.



If there are longer interruptions in the electricity distribution, thermostats should be set to the "0" position. This should be done in order to prevent unexpected start-up of the pan when the electricity distribution is restored.



Due to the very short preheating time of the bratt pan, energy can be saved by not switching the pan on until the frying is started. If there is a longer pause during the frying, the bratt pan can be switched off or the temperature can be set to a lower value. Energy can also be saved by keeping the lid closed always when possible, for instance when simmering or stewing.

#### 4.2.2. Setting of the frying temperature

The frying temperature can be changed by turning the thermostat knob to the desired temperature. When lowering the temperature, some time will be needed for the frying surface to cool down. Increasing of the temperature turns on the yellow pilot light. The new temperature is reached when the yellow light goes off.

On the Futura HD 150L and Futura HD 200L model, the frying surface has been divided into two frying zones that can be controlled separately. This makes it possible to fry two product types requiring different frying temperatures at the same time. By turning the thermostat to the 0 position, the other zone can be switched off when lower frying capacity is needed.

Futura HD 100L has only one cooking zone.



During long-time use, heat is transferred from one zone to the other. Although one zone would be switched off, it gets gradually warm, reaching a temperature that is about half of the temperature of the heated zone. If so desired, the temperature of this zone can be checked by turning the thermostat knob to a position where the yellow pilot light goes on.



**Max. possible working temperature for this model of bratt is 250°C. It is not possible to set working temperature over 250°C. The rotating knob of the thermostat will not go over mark "250°C". Do not try to apply force to override this mark.**

#### 4.2.3. Frying temperature

Guiding temperatures for various products:

Fried eggs	150°C
Omelette	160°C
Fish	170°C
Bacon	150°C
Meat cubes	170°C
Meat balls, depending on size	130°C.....170°C
Hamburgers, depending on size	130°C.....170°C
Veal fillet	170°C
Wiennasteak	170°C
Thin steak of veal	220°C
Broiler, big pieces	150°C
Floured slices of liver	170°C
Chops	170°C
Sausage cubes	130°C.....150°C
Frankfurters	150°C
Fried potatoes	150°C.....170°C
Mushrooms	130°C.....150°C
Onion	140°C
Small pancakes	170°C

#### 4.2.4. Tilting





Before tilting or returning the pan bowl to the working position, check that nothing is in the movement area or leaning against the moving part of the bratt pan.



Check that lid of bratt pan is in opened position. Tilting is not allowed if the lid is closed.

### Tilting via control panel

To tilt bowl at desired angle push and hold  button. Release button when bowl has reached desired position. Tilting will be stopped automatically when bowl has reached max. tilting angle. Tilting is not allowed if the lid is closed.

To return bowl to working (horizontal) position push and hold  button until bowl is stopped in horizontal position.

### Tilting via optional wired remote control

Holding the remote control in hands, push and hold  button to tilt bowl at desired angle. Release button when bowl has reached desired position.

To return bowl to working (horizontal) position push and hold  button until bowl is stopped in horizontal position.

Discharging of bowl fully filled by water or liquid product must be carried out with great care to avoid

overflow of product besides pouring spout through front part of the bowl. Start tilting by pushing  button and holding it short time then release button to allow product partly to pour out. Repeat such action few times until steady stream will be established.

When tilting the pan bowl, the heating is switched off and will be switched on again when the pan is in the horizontal position.

### 4.2.5. Filling the water (optional)

Filling the cold water is possible when bowl is in horizontal position and lid of bratt pan is opened. Push and hold  button on the operating panel. Wait until required amount of water collected and release button.

## 4.3. After use

### 4.3.1. Cleaning

Burned deposits on the frying surface of the pan form an isolating layer which slows up the frying and creates poor frying results. A clean frying surface is a must for good-quality results.



The effect of burned deposits on the surface temperature: 2 mm of deposits lower the surface temperature with 24 % (180°C => approx. 135°C).

**Cleaning equipment:**

- scraper, hard brush, scouring plate, towel, kitchen paper

**Cleaning detergent:**

- slightly alkaline detergent (pH 8-10)

**Cleaning method:**

- scraping, dry, wet, damp

**Precleaning:**

- Scrape out frying remains and wipe out grease and loose remains with paper. When necessary, pour hot water into the pan and let soak.

**Cleaning:**

- The inside of the pan bowl is cleaned with a brush and hot water. Spots are removed with a scouring plate. Cleaning detergent should be used only for frying surfaces extremely covered with burned deposits, because it removes grease from the frying surface.
- Inner and outer surfaces of the lid are cleaned with a brush and cleaning detergent solution.
- The outer surfaces of the pan are cleaned with a brush and cleaning detergent solution and rinsed with water.

**After cleaning:**

- The frying surface of the pan is rinsed with hot water, dried by heating up and greased with salt-free grease. All other surfaces are rinsed and wiped dry.



Water usage on the control panel must be avoided.



Use of a water hose or pressure cleaning jet is strictly forbidden.



In order to remain in good condition, the frying surface must be burned with salt-free grease when the pan is taken into use for the first time, and after that at intervals during use. This is especially necessary in connection with thorough cleaning.

#### 4.3.2. Service



Switch the appliance off if it is damaged or is malfunctioning. Contact authorized service personnel using original spare parts for service of the appliance.



The appliance does not include any user serviceable parts inside. Service must be left to authorized service personnel.

## 5. Installation

### 5.1. General



Please observe the instructions given in this chapter concerning the installation and adjustments that must be done taking the bratt pan into use. Strict observance of the instructions prevents malfunctions and damages potentially caused by defective installation.

#### 5.1.1. Operating conditions

The Futura HD bratt pan can be used in a normal, air-conditioned professional kitchen. The room temperature of the installation place must not exceed +40°C and the relative humidity must be less than 80% (condensation on surfaces not allowed to occur).

#### 5.1.2. Storage

The Futura HD bratt pan must be stored in a dry place, at a temperature between +10 and +40°C. The bratt pan should be kept in its transport package during storage.

If the appliance is stored in construction site conditions, special care must be taken not to damage it through other operations on the site:

- Protect the exterior of the bratt pan from scratches and knocks.
- Protect the bratt pan from construction site dust.
- Protect the bratt pan from sparks produced by welding, grinding and abrasive cutting wheels. These can later cause rust spots on the stainless steel surface of the appliance.
- If the temperature of the facility in winter conditions is below 0°C, the solenoid valve body and rubber hoses must be emptied at the same time. Solenoid valve and hoses are located inside support (left) pillar. To get access inside pillar remove side panel by loosen two screws near lower edge of side panel.\*

\*Requirement valid only for bratt pans with accessories:

- water filling
- hose reel with hand shower.

### 5.2. Transporting and unpacking the bratt pan

The best way to move bratt pan is to keep it in its own package as long as possible, while it also protects the pan from outer damage. If it is necessary to unpack the pan, possible lifting must thereafter be done by using pallet jack.

In order to avoid damage, it is not allowed to use the lid as a workbench during installation.

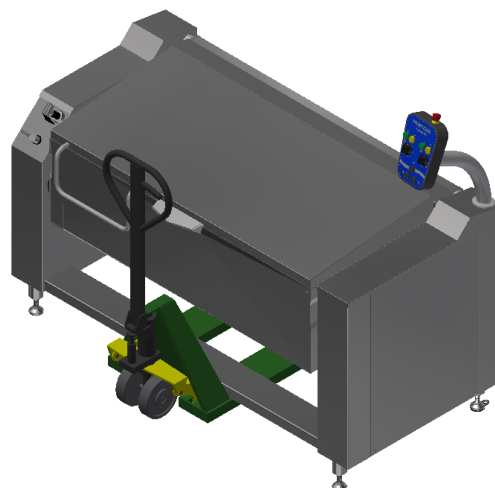

### 5.3. Positioning the bratt pan

The installation is started by moving the pan exactly to the right installation spot considering a possible floor drain. The distances needed are shown in the installation drawing.

#### 5.3.1. Leveling of the bratt pan

The pan is delivered leveled at height 900mm (refer to installation drawing).

If leveling at place is necessary, it is done by turning the adjustable feet. The correct position is checked by means of bubble level, placed on base of the bowl. Open the lid and check level from the right to the left. Adjust if necessary, by turning left front foot.

Check level from front to rear. Adjust rear left foot if necessary.

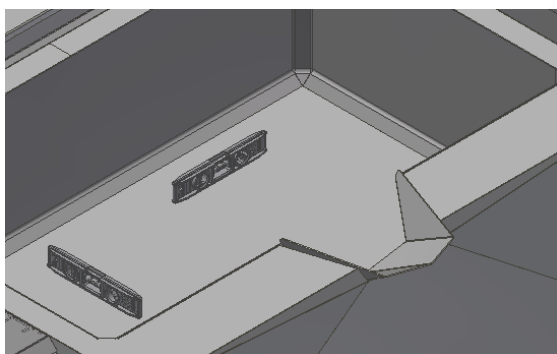

Check position of bowl support screws. It should lay on the support bracket. Adjust if necessary.

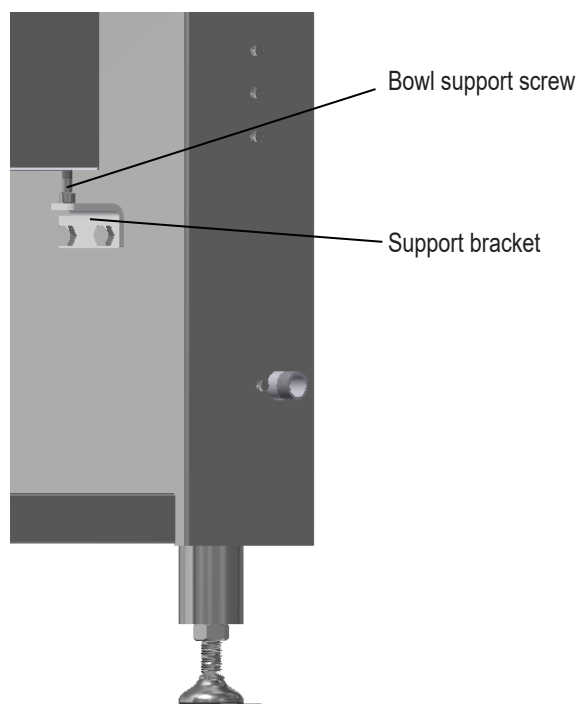



When the bratt pan is on the correct location and in a horizontal position, it can be bolted to the floor using flanges on the rear feet.

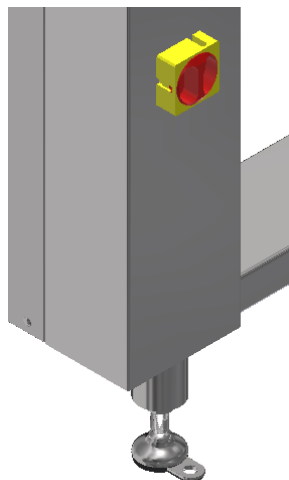

### 5.4. Connections

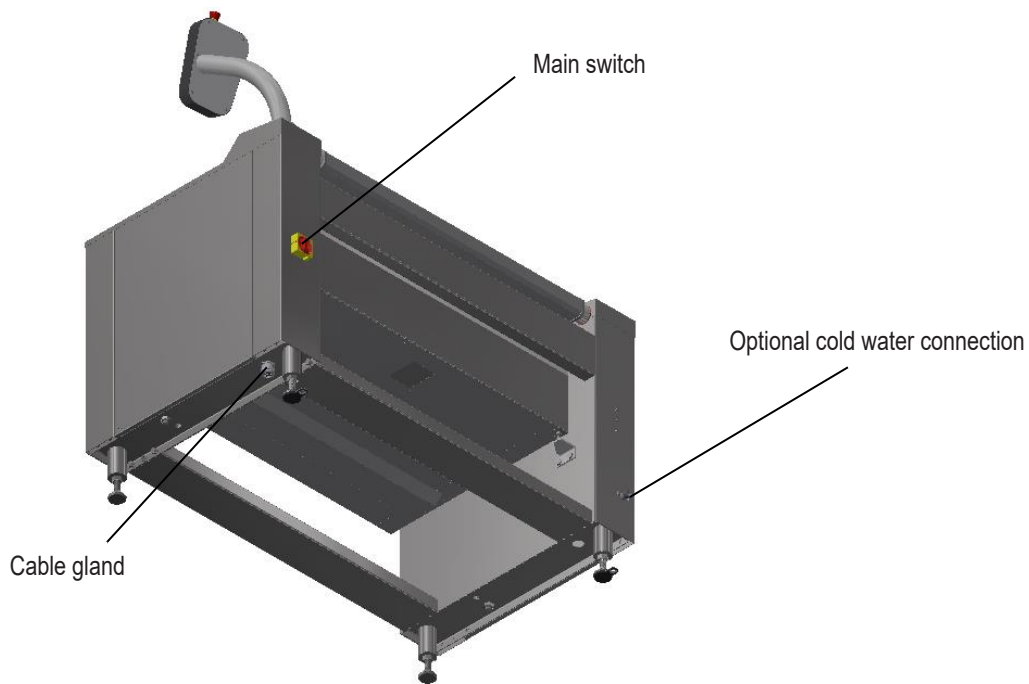

### 5.4.1. Electrical connection

Cable gland for supply cable is located on the bottom of control pillar. Refer to installation drawings for the size of power supply cable needed. In order to make connection, the side cover of control pillar must be removed. To remove side cover, loosen two screws that are located near lower edge. Supply cable should be 1m length from floor level for the purpose to be connected to terminals of main switch.



In order to make eventual future service easier and to increase safety, a mains switch must be installed near the appliance. This switch must disconnect the appliance completely from the electrical supply network.

### 5.4.2. Water connection (optional)



Connection to cold water supply must be made by pressure resistant hose (not included in delivery) fitted with G 3/4 connector. The water connection must be fitted with shut-off valve and non-return valve (not included in delivery). Cold water supply pressure must be within 20kPa...80kPa. Rinse the water hose before making the water connection.



## 5.5. Test-run



Besides the live electrical parts also look out for possible moving mechanisms inside pillars, if there is a need for testing the appliance during installation while cover plates are detached.

When electrical and water connection are ready turn main switch in "I" position and check the function of the bratt pan.

Check that:

- Tilting of bowl begins when lid is open and when  button held pushed
- Bowl returns in home (horizontal) position when  button held pushed
- Water starts to run when lid is opened, bowl is in home position, and  button held pushed
- When turning the thermostat knob, both the green and yellow pilot light goes on
- The yellow pilot light goes off after a few minutes when the frying surface has reached the set temperature
- The yellow pilot light goes off after tilting has started and goes on again when bowl has returned to home (horizontal) position.





The bratt pan Futura HD 150L and Futura HD 200L are equipped with two safety thermostats. Bratt pan Futura HD 100L is equipped with one safety thermostat. Safety thermostat prevents bratt pan from overheating if main thermostat does not switch off heating elements.

After installation of the bratt pan during test-run check the condition of safety thermostat. If after turning the main thermostat knob at desired temperature green pilot lamp goes on but yellow pilot lamp remains off than safety thermostat need to be reset. Contact an authorized service person to reset safety thermostat.



## 6. Troubleshooting

### 6.1. Troubleshooting Futura HD 100

MALFUNCTION	POSSIBLE REASON	WHAT TO DO
The pan does not heat	The mains switch Q1 is in position 0.*	Turn the switch to position I.
	The emergency-stop switch S5 is pressed down.*	Release the emergency-stop switch by turning it clockwise.
	One of the fuses F1 or F2, or F3, or F4 is blown.*	Turn the mains switch to position 0. Change the fuse. Turn the mains switch to position I.
	Pan is not returned to home (horizontal) position.	Push and hold  button until pan stops in home position.
	Thermostat A1 faulty.*	Contact qualified technical personnel.
	Safety thermostat S2 has tripped.*	Contact qualified technical personnel.
	Transformer T1 is broken/blown.*	Contact qualified technical personnel.
Heating of the pan is slow	One or few heating elements E burnt.*	Contact qualified technical personnel.
The pan is overheated	Thermostat S1 and safety thermostat S2 faulty.*	Contact qualified technical personnel.
Pan does not tilt/return	The mains switch Q1 is in position 0.*	Turn the switch to position I.
	The emergency-stop switch S5 is pressed down.*	Release the emergency-stop switch by turning it clockwise.
	One of the fuses F1 or F2, or F3, or F4 is blown.*	Turn the mains switch to position 0. Change the fuse. Turn the mains switch to position I.
	Transformer T1 is broken/blown.*	Contact qualified technical personnel.
	Switch S8 or S10 is broken.*	Contact qualified technical personnel.
	Tilting control unit faulty.*	Contact qualified technical personnel.
	Tilting actuator M1 or M2 faulty.*	Contact qualified technical personnel.
Water filling does not work	Shut-off valve on water supply line outside bpatt pan is closed.	Check shut –off valve position. Open if it is closed.
	The mains switch Q1 is in position 0.*	Turn the switch to position I.
	The emergency-stop switch S5 is pressed down.*	Release the emergency-stop switch by turning it clockwise.
	One of the fuses F1 or F2, or F3, or F4 is blown.*	Turn the mains switch to position 0. Change the fuse. Turn the mains switch to position I.
	Pan is not returned to home (horizontal) position.	Push and hold  button until pan stops in home position.
	Switch S7 (Water filling) is broken.*	Contact qualified technical personnel.
	Solenoid valve V1 is broken.*	Contact qualified technical personnel.

\*Refer to wiring diagram in section 7.

## 6.2. Troubleshooting Futura HD 150, Futura HD 200

MALFUNCTION	POSSIBLE REASON	WHAT TO DO
The pan does not heat	The mains switch Q1 is in position 0.*	Turn the switch to position I.
	The emergency-stop switch S5 is pressed down.*	Release the emergency-stop switch by turning it clockwise.
	One of the fuses F1 or F2, or F3, or F4 is blown.*	Turn the mains switch to position 0. Change the fuse. Turn the mains switch to position I.
	Transformer T1 is broken/blown.*	Contact qualified technical personnel.
	Pan is not returned to home (horizontal) position.	Push and hold  button until pan stops in home position.
	Transformer T1 is broken/blown.*	Contact qualified technical personnel.
	Thermostat A1 or A2 faulty.*	Contact qualified technical personnel.
	Safety thermostat S3 or S4 has tripped.*	Contact qualified technical personnel.
Heating of the pan is slow	One or few heating elements E burnt.*	Contact qualified technical personnel.
The pan is overheated	Thermostat A1 and safety thermostat S3 faulty.*	Contact qualified technical personnel.
	Thermostat A2 and safety thermostat S4 faulty.*	Contact qualified technical personnel.
Pan does not tilt/return	The mains switch Q1 is in position 0.*	Turn the switch to position I.
	The emergency-stop switch S5 is pressed down.*	Release the emergency-stop switch by turning it clockwise.
	One of the fuses F1 or F2, or F3, or F4 is blown.*	Turn the mains switch to position 0. Change the fuse. Turn the mains switch to position I.
	Transformer T1 is broken/blown.*	Contact qualified technical personnel.
	Switch S8 or S10 is broken.*	Contact qualified technical personnel.
	Tilting control unit faulty.*	Contact qualified technical personnel.
	Tilting actuator M1 or M2 faulty.*	Contact qualified technical personnel.
Water filling does not work	Shut-off valve on water supply line outside bpatt pan is closed.	Check shut –off valve position. Open if it is closed.
	The mains switch Q1 is in position 0.*	Turn the switch to position I.
	The emergency-stop switch S5 is pressed down.*	Release the emergency-stop switch by turning it clockwise.
	One of the fuses F1 or F2, or F3, or F4 is blown.*	Turn the mains switch to position 0. Change the fuse. Turn the mains switch to position I.
	Pan is not returned to home (horizontal) position.	Push and hold  button until pan stops in home position.
	Switch S8 (Water filling) is broken.*	Contact qualified technical personnel.
	Solenoid valve V1 is broken.*	Contact qualified technical personnel.

\*Refer to wiring diagram in chapter 7

The appliance does not include any user serviceable parts inside. Service must be left to authorized service personnel.

When you contact service personnel, give the following information for the unit in question:

- What is the type and model of the unit.
- What is the serial number of the unit and the date the unit has been installed.
- A short description of the fault, what function is not working.
- What happened/was done immediately before the fault occurred.

## 7. Technical specifications

- Voltage codes
- Product codes
- Heating element connection T04466B3
- Heating element connection T04467A3
- Heating element connection T04468A3
- Main and control circuit diagram T05416 (E)
- Main and control circuit diagram T05417 (D)
- Main and control circuit diagram T05470 (E)
- Main and control circuit diagram T05471 (C)
- Main and control circuit diagram T05472 (E)
- Main and control circuit diagram T05473 (E)
- Installation drawing T04513C3
- Installation drawing T04532C3
- Installation drawing T04569C3

## Voltage codes

Voltage code	Voltage
A	3/N/PE~400/230V 50Hz
B	~250V 16A 50Hz
C	3/N/PE~380/220V 50Hz
D	3/PE~200V 50-60Hz
F	2/PE 220-240V 50Hz
G	3/N/PE~415/240V 50Hz
H	3/PE~230V 50Hz
I	3/PE~220V 60Hz
J	3/PE~380 50Hz
K	3/PE~400V 50Hz
L	3/PE~415V 50Hz
M	3/PE~440V 60Hz
N	3/PE~460V 60Hz
O	3/PE~480V 60Hz
P	1/N/PE~220-240V 50Hz
R	2/PE~220-230V 60Hz

## Product codes

Type codes	Full name	Description
100	Futura HD	
150	Futura HD	
200	Futura HD	



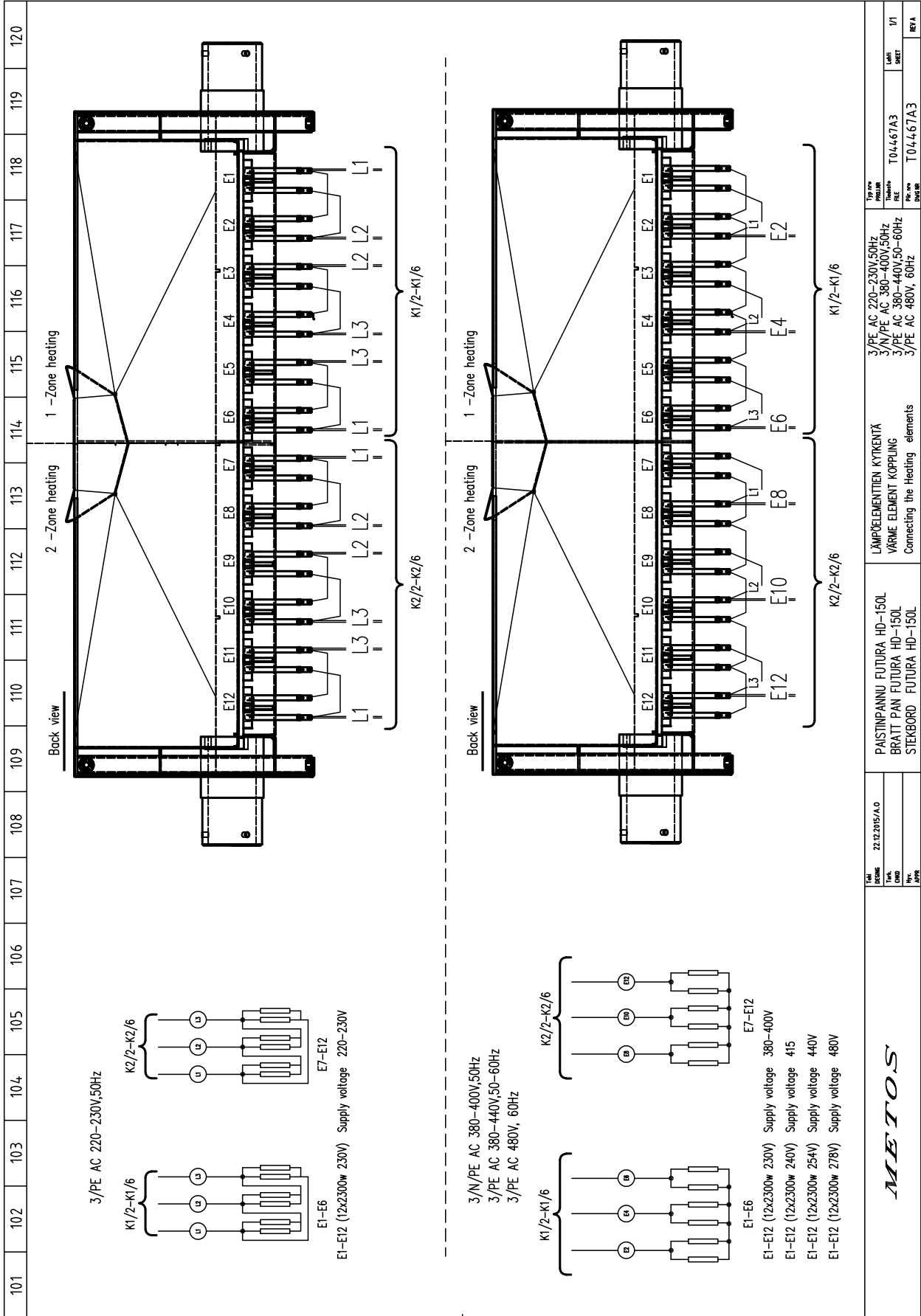

<p>PAISTIPANNU FUTURA HD-150L BRATT PAN FUTURA HD-150L STEBORD FUTURA HD-150L</p>	<p>LÄMPÖELEMENTTIEN KYTKENTÄ VARME ELEMENT KÖPPLING Connecting the Heating elements</p>	<p>3/PE AC 220-230V,50Hz 3/N/PE AC 380-400V,50Hz 3/PE AC 380-440V,50-60Hz 3/PE AC 480V, 60Hz</p>	<p>Typ. nro Tilaus nro Tilaus nro Tilaus nro Tilaus</p>	<p>T04467A3 T04467A3</p>	<p>1/1 REVA</p>
---	---	--	---	------------------------------	---------------------

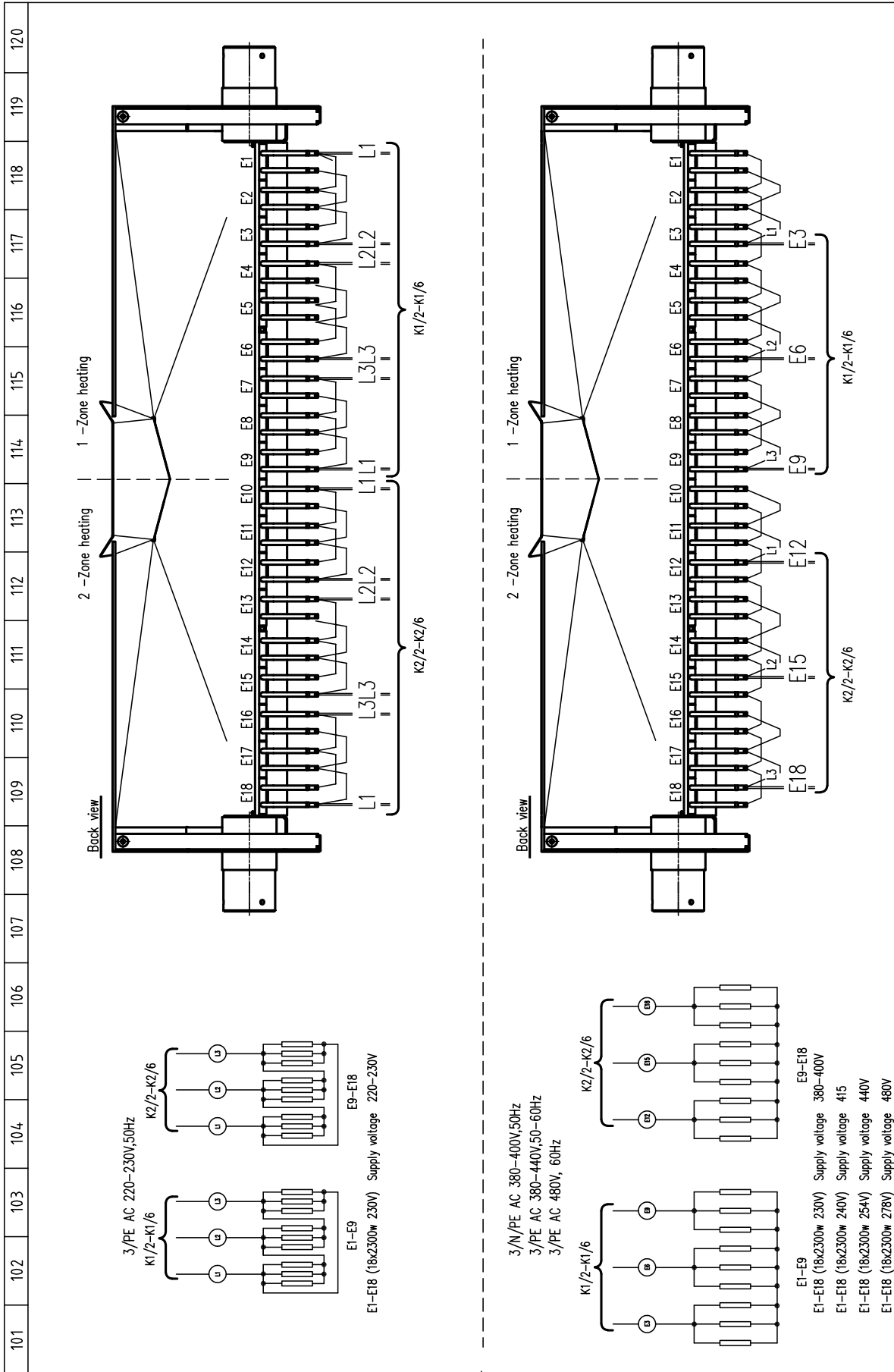

101	102	103	104	105	106	107	108	109	110	111	112	113	114	115	116	117	118	119	120
<p>3/PE AC 220-230V,50Hz K1/2-K1/6</p> <p>E1-E9</p> <p>3/PE AC 220-230V,50Hz K2/2-K2/6</p> <p>E9-E18</p> <p>E1-E18 (18x2300w 230V) Supply voltage 220-230V</p>		<p>3/N/PE AC 380-400V,50Hz 3/PE AC 380-440V,50-60Hz 3/PE AC 480V, 60Hz</p> <p>K1/2-K1/6</p> <p>K2/2-K2/6</p> <p>E1-E18 (18x2300w 230V) Supply voltage 380-400V E1-E18 (18x2300w 240V) Supply voltage 415 E1-E18 (18x2300w 254V) Supply voltage 440V E1-E18 (18x2300w 278V) Supply voltage 480V</p>		<p>Back view</p> <p>2 -Zone heating</p> <p>1 -Zone heating</p> <p>E18 E17 E16 E15 E14 E13 E12 E11 E10 E9 E8 E7 E6 E5 E4 E3 E2 E1</p> <p>L1 L2 L3</p> <p>K1/2-K1/6</p> <p>K2/2-K2/6</p>		<p>Back view</p> <p>2 -Zone heating</p> <p>1 -Zone heating</p> <p>E18 E17 E16 E15 E14 E13 E12 E11 E10 E9 E8 E7 E6 E5 E4 E3 E2 E1</p> <p>L1 L2 L3</p> <p>K1/2-K1/6</p> <p>K2/2-K2/6</p>		<p>PAISTINPANNU FUTURA HD-200L BRATT PAN FUTURA HD-200L STIEKBORD FUTURA HD-200L</p> <p>LAMPÖLEMENTTIN KYTKENTÄ VÄRME ELEMENT KOPPLING Connecting the Heating elements</p> <p>3/PE AC 220-230V,50Hz 3/N/PE AC 380-400V,50Hz 3/PE AC 380-440V,50-60Hz 3/PE AC 480V, 50-60Hz</p>		<p>TYP-NR PROJEKT RELE PER-NR DIN-NR</p> <p>T04.468A3 T04.468A3</p>		<p>1/1 SHEET</p>		<p>REF A</p>					

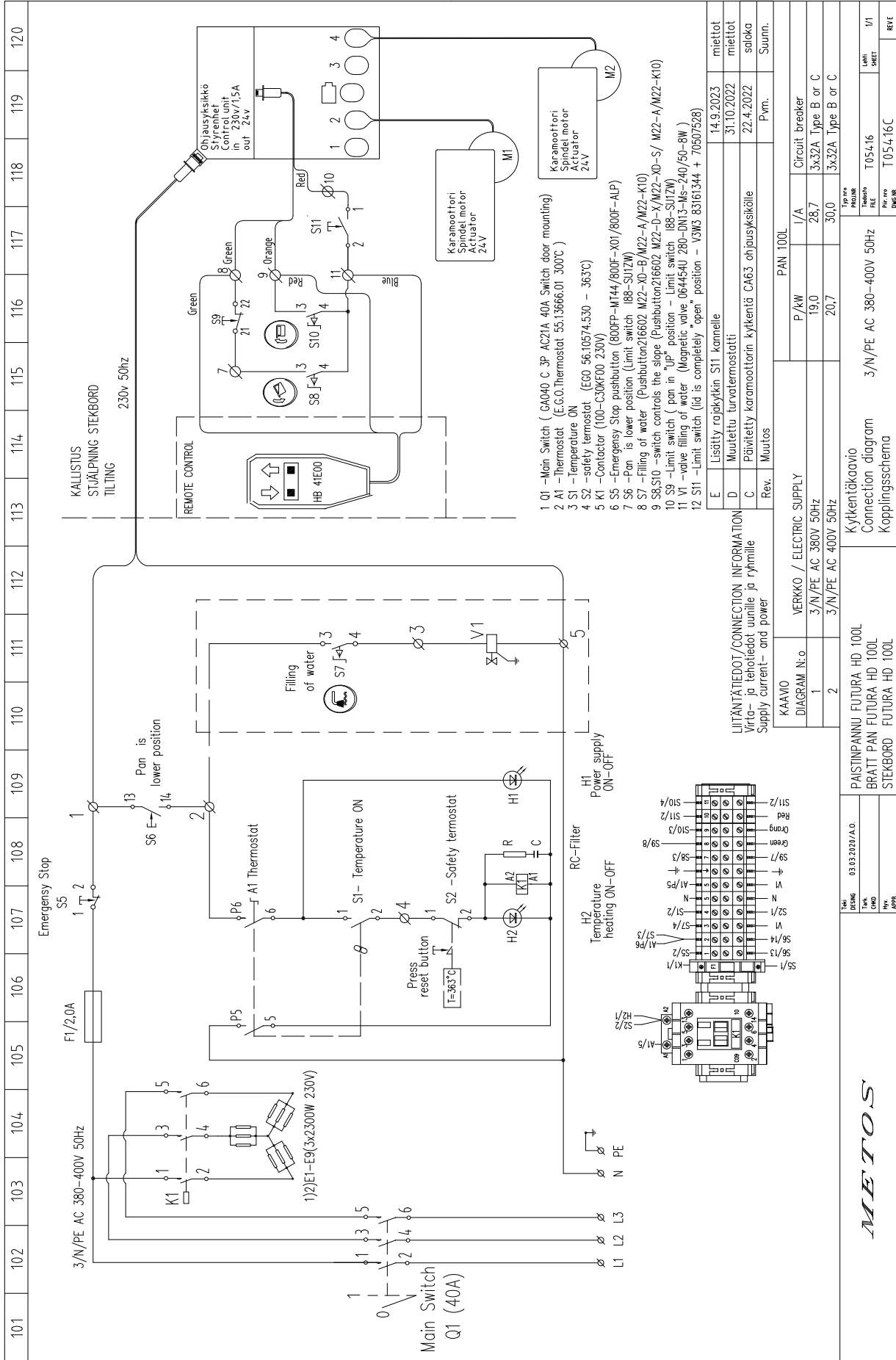



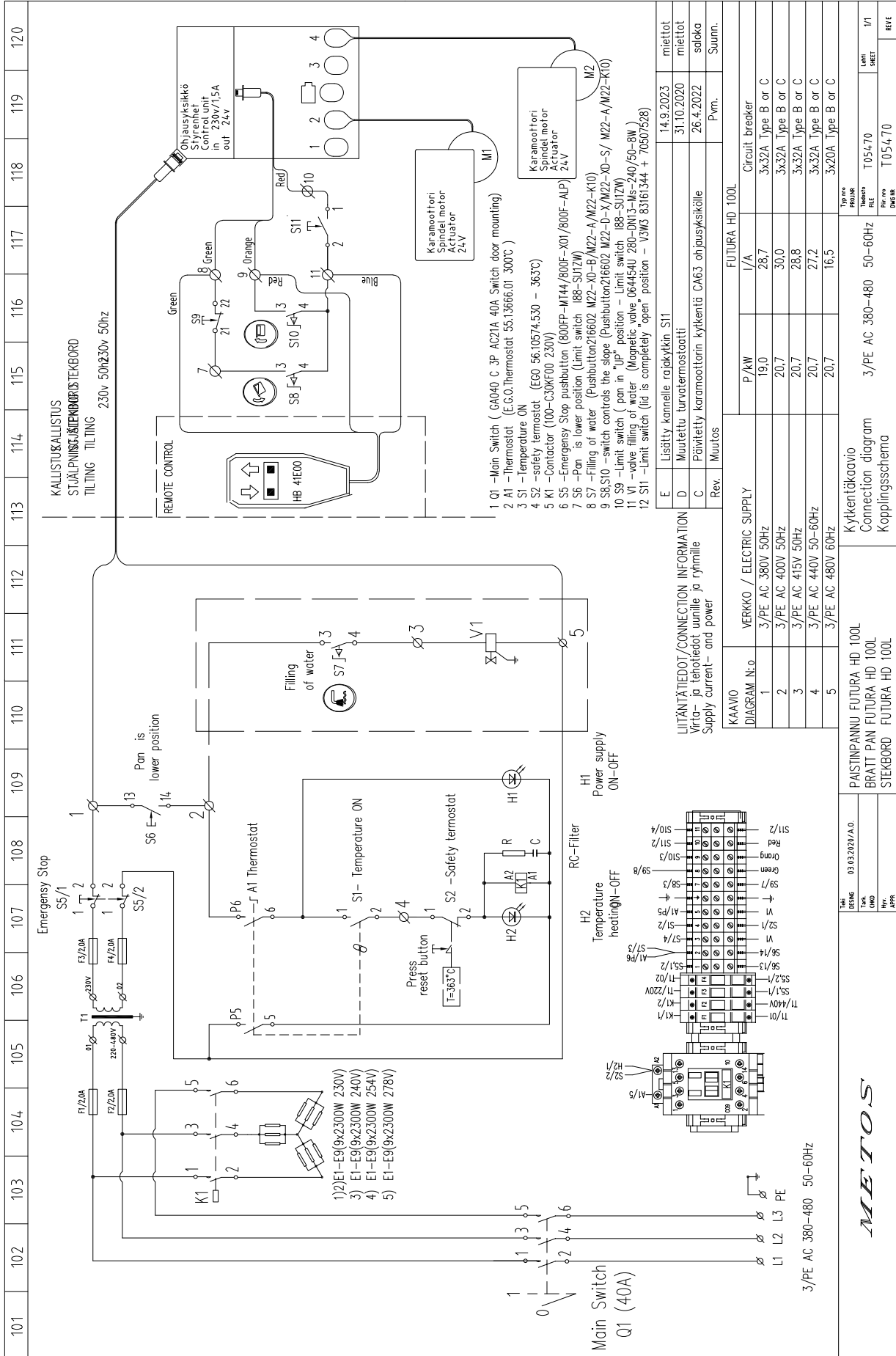

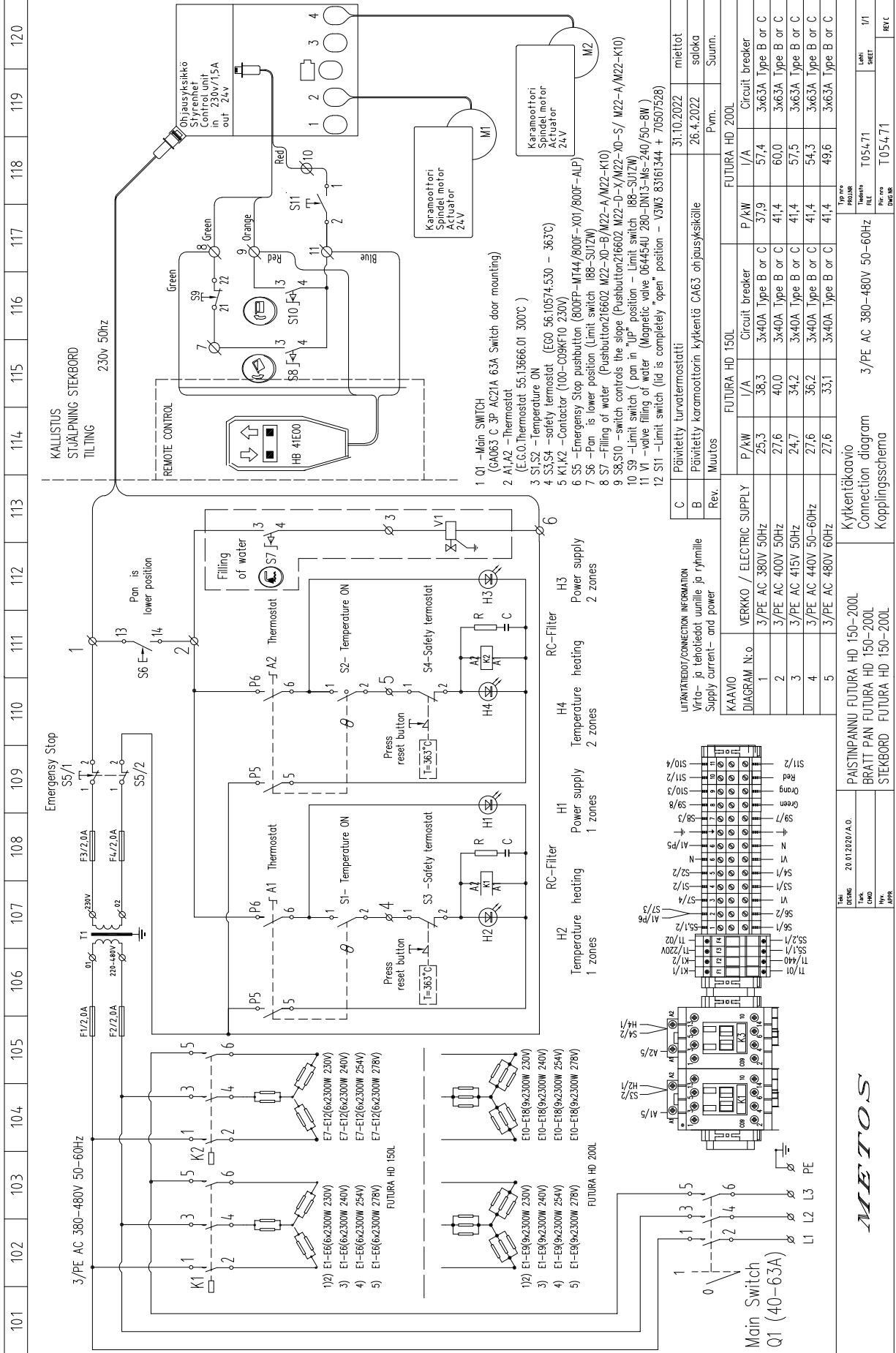

101 102 103 104 105 106 107 108 109 110 111 112 113 114 115 116 117 118 119 120

KALLISTUS  
STJÄLPNING STEKBORD  
TILTING

230v, 50Hz

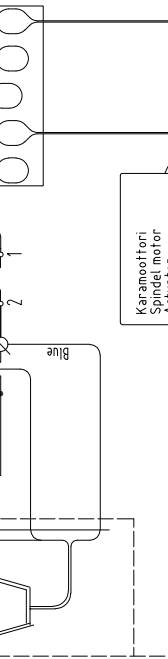
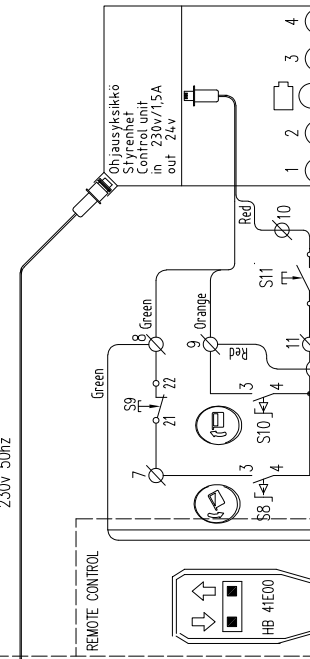

- 1 Q1 -Main SWITCH (GA063 C 3P AC21A 65A Switch door mounting)
- 2 A1,A2 -Thermostat (E.G.O.Thermostat 55:3666.01 300C )
- 3 S1,S2 -Temperature ON
- 4 S3,S4 -safety thermostat (ECO 56:10574.530 - 363°C)
- 5 K1,K2 -Contactor (100-Q09KF10 230V)
- 6 S5 -Emergency Stop pushbutton (800FP-MT44/800F-X01/800F-ALP)
- 7 S6 -Pan is lower position (Limit switch 188-SU1ZW)
- 8 S7 -Filling of water (Pushbutton216602 M22-XD-B/M22-A/M22-K10)
- 9 S8,S10 -switch controls the slope (Pushbutton216602 M22-D-X/M22-XD-S/ M22-A/M22-K10)
- 10 S9 -Limit switch ( pan in "Up" position - Limit switch 188-SU1ZW)
- 11 V1 -valve filling of water (Magnetic valve 064454U 280-DN13-MS-240/50-8W )
- 12 S11 -Limit switch (lid is completely "open" position - Y3W3 85161344 + 70507528)

Rev.	UUNNÄTTEDY/CONNECTION INFORMATION	VERKKO / ELECTRIC SUPPLY	I/A	Circuit breaker	P/kW	I/A	Circuit breaker	P/kW	I/A	31.10.2022	mieltoet
C	Virto- ja tehoteetot uunille ja ryhmille	3/PE AC 380V 50Hz	38,3	3x40A Type B or C	25,3	38,3	3x40A Type B or C	37,9	57,4	26.4.2022	soikoa
B	Supply current- and power	3/PE AC 400V 50Hz	40,0	3x40A Type B or C	27,6	40,0	3x40A Type B or C	41,4	60,0		Suunn.
		3/PE AC 415V 50Hz	34,2	3x40A Type B or C	24,7	34,2	3x40A Type B or C	41,4	57,5		
		3/PE AC 440V 50-60Hz	36,2	3x40A Type B or C	27,6	36,2	3x40A Type B or C	41,4	54,3		
		3/PE AC 480V 60Hz	33,1	3x40A Type B or C	27,6	33,1	3x40A Type B or C	41,4	49,6		

Rev.	UUNNÄTTEDY/CONNECTION INFORMATION	VERKKO / ELECTRIC SUPPLY	I/A	Circuit breaker	P/kW	I/A	Circuit breaker	P/kW	I/A	31.10.2022	mieltoet
C	Virto- ja tehoteetot uunille ja ryhmille	3/PE AC 380V 50Hz	38,3	3x40A Type B or C	25,3	38,3	3x40A Type B or C	37,9	57,4	26.4.2022	soikoa
B	Supply current- and power	3/PE AC 400V 50Hz	40,0	3x40A Type B or C	27,6	40,0	3x40A Type B or C	41,4	60,0		Suunn.
		3/PE AC 415V 50Hz	34,2	3x40A Type B or C	24,7	34,2	3x40A Type B or C	41,4	57,5		
		3/PE AC 440V 50-60Hz	36,2	3x40A Type B or C	27,6	36,2	3x40A Type B or C	41,4	54,3		
		3/PE AC 480V 60Hz	33,1	3x40A Type B or C	27,6	33,1	3x40A Type B or C	41,4	49,6		

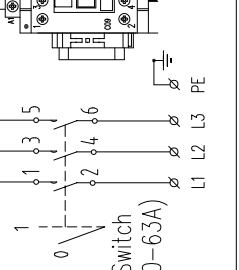
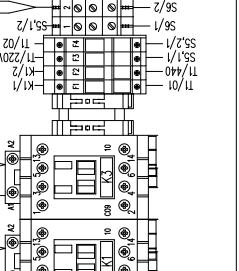
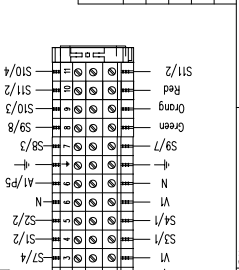

PAISTINPANNU FUTURA HD 150-200L  
BRATT PAN FUTURA HD 150-200L  
STEBKORB FUTURA HD 150-200L

Kytkentäkaavio  
Connection diagram  
Kopplingschema

20.07.2020/A.O.  
DENK  
Tark  
OHD  
Rev.  
PVL

3/P AC 380-480V 50-60Hz

FUTURA HD 200L

3/P AC 380-480V 50-60Hz

MEIOS







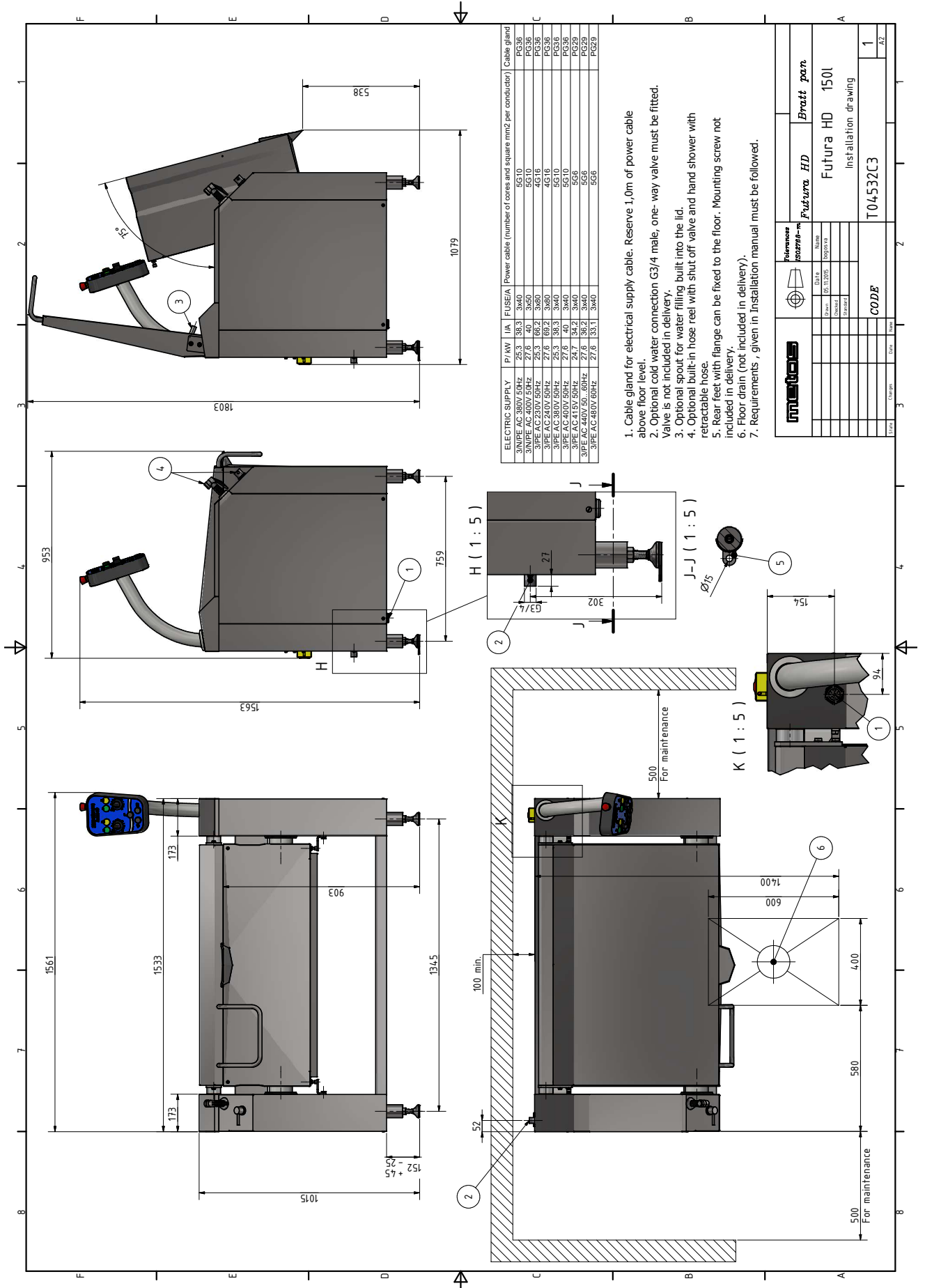

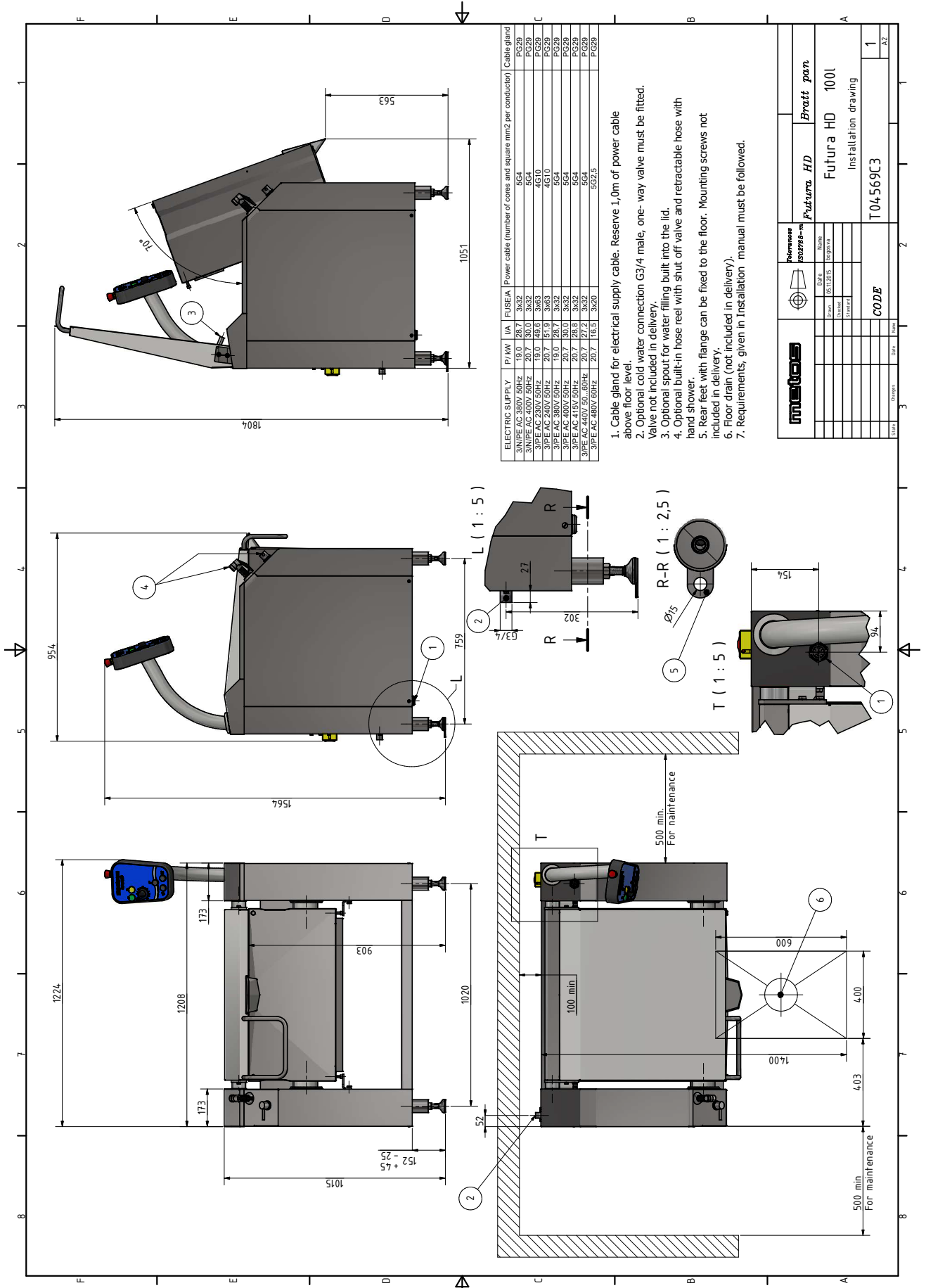

## Technical specifications table

Item	Type	Voltage	Specification
Dimensions WxDxH	100		1224x954x1563mm
	150		1561x953x1563mm
	200		1858x952x1563mm
Package dimensions WxDxH	100		1440x1090x1870
	150		1765x1290x1870
	200		2090x1290x1870
Working capacity	100		100L
	150		150L
	200		200L
Geometrical volume of bowl	100		116L
	150		170L
	200		225L
Depth of bowl	100		273mm
	150		
	200		
Frying surface	100		0,4m <sup>2</sup>
	150		0,59m <sup>2</sup>
	200		0,78m <sup>2</sup>
Number of frying zone	100		1
	150		2
	200		3
Number of GN 1/1 containers that can be placed in bowl	100		2
	150		3
	200		4
Temperature setting range	100 150 200		50°C...250°C
Main construction material of the bratt pan	100 150 200		Stainless steel 1.4016
Material of the base of bowl	100 150 200		Stainless steel 1.4016
Material of bowl in contact with food	100 150 200		Stainless steel 1.4301
Weigh without package	100		250kg
	150		320kg
	200		370kg
Weigh with package	100		330kg
	150		400kg
	200		460kg
Power	100	C,J A,K,L,M, O	19,0kW 20,7kW 20,7kW
Power	150	C,J A,K,M,O L	25,3kW 27,6kW 24,7kW
Power	200	C,J A,K,M,O G,L	37,9kW 41,4kW 41,4kW
Cold water connection	100,150,200		G3/4 male
Cold water supply pressure	100,150,200		20kPa...800kPa
Noise level	100,150,200		Below 70dB
Operating conditions			Normal, air-conditioned professional kitchen conditions. Room temperature must not exceed +40°C and the relative humidity must be less than 80%.

Valmistajan nimi / Tillverkarens namn / Manufacturer's name

**METOS OY AB**

Osoite / Adress / Address

04220 KERAVA  
FINLAND

Vakuuttaa, että seuraava tuote / Försäkrar att följande produkt / Declare that the following product

Nimi, tyyppi tai malli / Namn, typ eller modell / Name, type or model

Paistinpannu / Stekbord / Bratt Pann

**METOS Futura HD**

Mallit / Modeller / Models : 100, 150, 300 With accessories: hose reel spray Unit, remote control

**METOS Futura E/M**

Mallit / Modeller / Models : 85, 85L, 85D, 110, 110L, 110D With accessories: height adjustment, water tap, stainless steel bottom, manual tilting, wall installation

**METOS Prince**

Mallit / Modeller / Models : 60, 80 With accessories: height adjustment, water tap, stainless steel bottom

on seuraavien direktiivien asiaankuuluvien säännösten mukainen / överensstämmer med tillämpliga bestämmelser i följande direktiv / is in conformity with the relevant provisions of the following directives

MD 2006/42/EC, LVD 2014/35/EU, EMC 2014/30/EU, RoHS 2011/65/EC, WEEE 2012/19/EU

ja lisäksi vakuuttaa, että seuraavia yhdenmukaistettuja standardeja (tai niiden osia/kohtia) on sovellettu / och försäkrar dessutom att följande harmoniserade standarder (eller delar/paragrafer) har använts / and furthermore declares that the following harmonised standards (or parts/clauses) have been used

EN ISO 12100:2010, EN ISO 13857:2019, EN 61000-6-1:2019, EN 61000-6-3,  
EN 60204-1:2018

ja lisäksi vakuuttaa, että seuraavia muita standardeja (tai niiden osia/kohtia) on sovellettu / och försäkrar dessutom att följande andra standarder (eller delar/paragrafer) har använts / and furthermore we declare that the following other standards (or parts/clauses) have been used

EN 60335-1:2020, EN 60335-2-39:2012, EN 60335-2-36:2017, EN 60335-2-42

Alla mainittu henkilö on valtuutettu kokoamaan teknisen tiedoston / Nedan nämnda person är bemyndigad att sammanställa den tekniska dokumentfilen / The person mentioned below is authorized to compile the technical file

Risto Koskelainen

Metos Oy Ab, Ahjonkaarre, 04220 Kerava, Finland

Tämä vaatimustenmukaisuusvakuutus on annettu valmistajan yksinomaisella vastuulla. Edellä kuvattu vakuutuksen kohde on unionin asiaankuuluvan yhdenmukaistamislainsäädännön vaatimusten mukainen.

Denna EU-försäkran om överensstämmelse utfärdas på tillverkarens eget ansvar. Föremålet för försäkran ovan överensstämmer med den relevanta unionslagstiftningen om harmonisering.

This declaration of conformity is issued under the sole responsibility of the manufacturer. The object of the declaration described above is in conformity with the relevant Union harmonisation legislation

Antopaikka ja päivä / Utfärdad på ort och datum / Place and date of issue

KERAVA

30.11.2021

Vakuutuksen antajan nimi ja asema / Namn och befattning av personen som försäkrar / Name and title of declaring person

  
Hannu Ahola – Director of Business Unit

  
Marko Immonen – R&D Manager

Manufacturer's name <b>METOS OY AB</b>
Address <b>04220 KERAVA FINLAND</b>

Declare that the following product

Name, type or model <b>Bratt Pann METOS Futura HD</b> Models : 100, 150, 300 With accessories: hose reel spray Unit, remote control <b>METOS Futura E/M</b> Models : 85, 85L, 85D, 110, 110L, 110D With accessories: height adjustment, water tap, stainless steel bottom, manual tilting, wall installation <b>METOS Prince</b> Models : 60, 80 With accessories: height adjustment, water tap, stainless steel bottom
---

is in conformity with the essential requirements and other relevant requirements of the UK legislation. The products are in conformity with the relevant UK legislation

Electrical Equipment (Safety) Regulations 2016, Electromagnetic Compatibility (EMC) Regulations 2016, Machinery (Safety) Regulations 2008: Great Britain, The Restriction of the Use of Certain Hazardous Substances in Electrical and Electronic Equipment Regulations 2012, Regulations: Waste Electrical and Electronic Equipment (WEEE)
---

furthermore declares that the following harmonized standards (or parts/clauses) have been used

BS EN ISO 12100:2010, BS EN ISO 13857:2008, BS EN IEC 61000-6-1:2019, BS EN IEC 61000-6-3:2007, BS EN 60204-1:2018
--

and furthermore we declare that the following other standards (or parts/clauses) have been used

BS EN 60335-1:2012+A15:2021, BS EN 60335-2-42, BS EN 60335-2-36
---

The person mentioned below is authorized to compile the technical file

<b>Otto Miettinen Metos Oy Ab, Ahjonkaarre, 04220 Kerava, Finland</b>
---

This declaration of conformity is issued under the sole responsibility of the manufacturer. The object of the declaration described above is in conformity with the relevant UK legislation

Place and date of issue <b>KERAVA 31.12.2022</b>
---

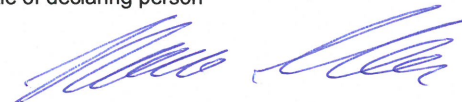
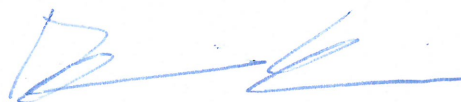
Name and title of declaring person  <b>Hannu Ahola – Director of Business Unit</b>	 <b>Risto Koskelainen – R&amp;D Manager</b>
---	--







**Metos Oy Ab**  
Ahjonkaarre FI-04220 Kerava, Finland  
tel. +358 204 3913  
[www.metos.com](http://www.metos.com)